

truecraft[®]

Product No. **18173**

Professional Hydraulic Wheel Changer



Operating Instructions



SPALDINGS[®]

Telephone: 01522 500600
Freefax: 0800 716040
E-mail: agsales@spaldings.co.uk
Web: www.spaldings.co.uk

EC DECLARATION OF CONFORMITY



Head office:
Spaldings Limited
Sadler Road, Lincoln LN6 3XJ
Tel: 01522 500600
Fax: 01522 509300
Email: sales@spaldings.co.uk

EC Declaration of conformity

In accordance with the 89/392EEC directive and subsequent modifications

Spaldings UK Limited
Sadler Road
Lincoln
LN6 3XJ

As the importer, hereby declare that the machine:

Model: Truecraft Hydraulic Wheel Changer
Product Code: 18173

To which this declaration relates, conforms with the following EC standards and directives

89/392/EEC: Essential safety requirements, as amended by 91/368, 93/4

93/68/EEC: CE Marking directive.

Signed:

A handwritten signature in black ink, appearing to be 'Nigel Whelan', written over a horizontal line.

Date: 10th April 2007

Name: Nigel Whelan

Position: Purchasing and Quality Control Manager

Europe's leading distributors of Agricultural and Groundcare replacement parts, tools and fasteners

www.spaldings.co.uk

Registered in England No. 01558147

Fig.1. Truecraft Wheel Changer EC declaration of conformity

CONTENTS

| | |
|---|---|
| 1 INTRODUCTION | |
| 1.0 Application, general description and features | 1 |
| 2 SAFETY GUIDELINES | |
| 2.0 Symbols | 2 |
| 2.1 Understanding the safety symbols | 2 |
| 2.2 General safety instructions | 2 |
| 2.3 Operator requirements | 2 |
| 3 PRODUCT OVERVIEW & SPECIFICATION | |
| 3.0 Product overview | 3 |
| 3.1 Technical specification | 3 |
| 4 INSTRUCTIONS FOR USE | |
| 4.0 Instructions for use | 4 |
| 5 MAINTENANCE | |
| 5.0 Refilling the hydraulic oil | 5 |

INTRODUCTION**1.0 The Truecraft Professional Hydraulic Wheel Changer**

Designed for effortless, fast and safe removal, handling and fitting of agricultural, industrial and commercial wheels.

The Truecraft Wheel Changers' lifting action is achieved using a two stage hydraulic pump, mounted inside the frame.

The wheel to be handled is lifted on two tables of rollers, one mounted on each leg. The hydraulic pump draws the legs together under the wheel so that the wheel is lifted by the rollers and a safety lock applied. The wheel is balanced securely using the integral wheel support before manoeuvring.

Features

- 2-speed hydraulic ram for quick and accurate adjustment
- Adjustable angle of retaining arm, can be used right or left handed, to allow better access in restricted areas
- 2 Support handles to assist with ease of manoeuvrability
- Adjustable retaining arm
- 4 heavy duty caster wheels to enable ease of movement once the wheel is on the roller table
- 2 roller tables each with 4 rollers to enable rotation of wheel for alignment to studs

SAFETY GUIDELINES

2.0 Safety symbols

The operator must fully understand the warning symbols on the machine.

The symbols are used to highlight important information:



DANGER

To draw the operator's attention to situations which could endanger his or other peoples safety.

CAUTION

To draw the operator's attention to situations which could affect the machine performance but not his or other peoples safety.

IMPORTANT

To draw the operator's attention to situations which do not affect the machine performance and his or other peoples safety.

It is important to comply with the instructions given by the safety stickers, which must always be on the machine. If new stickers are required, contact Spaldings.

The manufacturer is not responsible for any consequence due to the inobservance of these instructions.

2.1 Understanding the safety symbols

Before operating the machine, it is important that each operator understands the following explanations.

| SAFETY SYMBOL | SYMBOL MEANING |
|---------------|--|
| | <p>Before operation</p> <p>1. Before operating, adjusting or servicing the machine, it is important that each operator carefully reads the operating instructions.</p> |
| | <p>During operation</p> <p>2. Danger from unsecured load. The operator must ensure that wheels to be carried by the machine are correctly loaded and supported in accordance with the operating instructions.</p> |
| | <p>3. Always use the locking mechanism which locks the lifting rollers in position before manoeuvring the loaded wheel changer.</p> |
| | <p>4. Potential slip/fall hazard. Never stand or ride on the wheel changer when working with the machine.</p> |

2.2 General safety instructions

The following safety points must be observed when using the Truecraft Professional Hydraulic Wheel Changer.

- The operator should be experienced and in good health to avoid danger to himself and others.
- Never use the Wheel Changer unit for wheels of larger diameter, wider or heavier than those stipulated in the technical specification.
- The wheel supports (D) and clamp support arm (E) are only to be used to balance the wheel, NOT to carry a load!
- The wheel changer unit must only be used on horizontal workshop floors, swept clean of any debris. The use of the unit on a sloping surface is absolutely forbidden.
- Never drive the unit over edges, rough surfaces, or corners etc. when there is a load on it as the whole unit can overturn.
- It is of the greatest importance for safety that the unit is secured by the locking mechanism (F) on the nearest hole before manoeuvring the unit. If this lock is not used, the wheel changer could come apart while carrying the load, and the wheel could tip out.
- Always stand and operate the unit from behind the wheel supports (D).
- Do not operate or manoeuvre the wheel from in front of the wheel support arm (E).
- When refilling the oil reservoir, the unit must be pumped fully apart before the refill screw (G) is removed otherwise there is a risk of excess pressure in the reservoir which can cause oil to squirt out when the refill screw is loosened.
- Any possible spills of liquid etc, must be immediately taken care of to avoid risk of slippery surfaces.
- For the handling and destruction of oil, contact the nearest environmental authority.

2.3 Operator requirements

- The operator must be in good health with good sight and hearing and the physical ability to carry out all operations required.
- The operator must understand how the machine works, be responsible when operating the machine and aware of potential danger.
- The operator must have read this booklet and fully understand the warning symbols on the machine.

PRODUCT OVERVIEW & SPECIFICATION

3.0 Product Overview

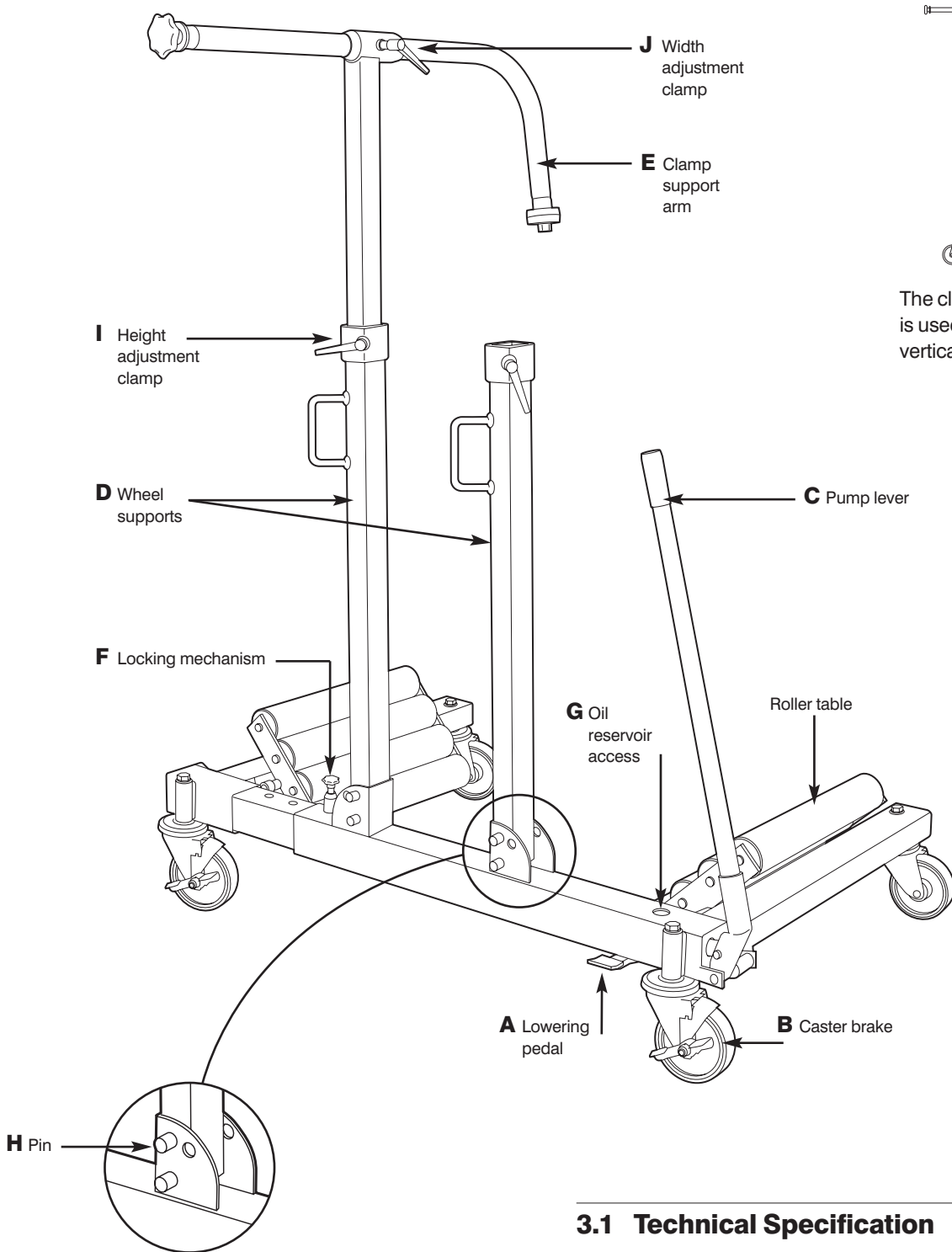

The clamp support arm (E) is used to balance the wheel vertically on the roller tables.

The angle of each wheel support can be adjusted by the removal of pin (H) to accommodate different wheel configurations.

3.1 Technical Specification

Truecraft Professional Hydraulic Wheel Changer:

- Spaldings product no: 18173
- Maximum load capacity: 1500Kg
- Dimensions: (W)1300 x (D)1015 x (H)1500mm
- Weight: 118Kg
- Minimum wheel diameter: 1000mm
- Maximum wheel diameter: 2200mm
- Maximum wheel width: 800mm

INSTRUCTIONS FOR USE**4.0 Using the wheel changer to remove a wheel**

Position the vehicle on a suitable horizontal floor, applying the break. Jack up the axle of the wheel to be changed, with a suitable trolley jack, so that it is clear of the floor. Secure with axle stands.

1. Using the wheel changer, press down the lowering pedal (A) and then pump apart the wheel changer with the pump lever (C).
2. Adjust the wheel support (D) so that the clamp support arm (E) is positioned over the wheel to be handled.
3. Push the wheel changer unit under the wheel so that the roller tables are positioned either side of the wheel and that the wheel sits up against the vertical wheel supports (D).
4. Check that the lowering pedal (A) is in its uppermost position, then pump the unit together until the wheel and unit cannot glide apart.
5. Lower clamp support arm (E) behind the wheel and adjust until the wheel is vertical and can be moved approx 5cm sideways, this will allow the wheel to be rotated in the wheel changer when re-locating wheel studs. Lock the clamp support arm in position by tightening adjustment clamps (I and J).

NOTE: The angle of the wheel supports can be adjusted by the removal of pin (H) to accommodate different wheel configurations.

WARNING:
WHEEL SUPPORT (D) AND CLAMP SUPPORT ARM (E) ARE ONLY USED TO BALANCE THE WHEEL NOT TO CARRY A LOAD!

6. Lift the wheel, by pumping the level (C). When the wheel is positioned on the unit the wheel changer must be secured in the lifting position with the locking mechanism (F).

IMPORTANT:
Ensure that locking mechanism (F) is secured through the nearest location hole on the inner member. This prevents unintentional lowering of the wheel while it is being handled.

7. With the wheel nuts removed, the wheel can now be safely carried away on the wheel changer.

4.1 Unloading the wheel changer

When the wheel is located on the wheel studs and secured with wheel nuts or the wheel has been moved to a place for storage, the wheel can be released.

1. Loosen clamp support (E) by releasing adjustment clamps (I and J).
2. Lift and release the locking mechanism (F).
3. Press down lowering pedal (A) and then pump apart the wheel changer with the pump lever (C).
4. Adjust the wheel support arm (E) so that it does not catch on the top of the wheel before manoeuvring the wheel changer clear of the wheel.

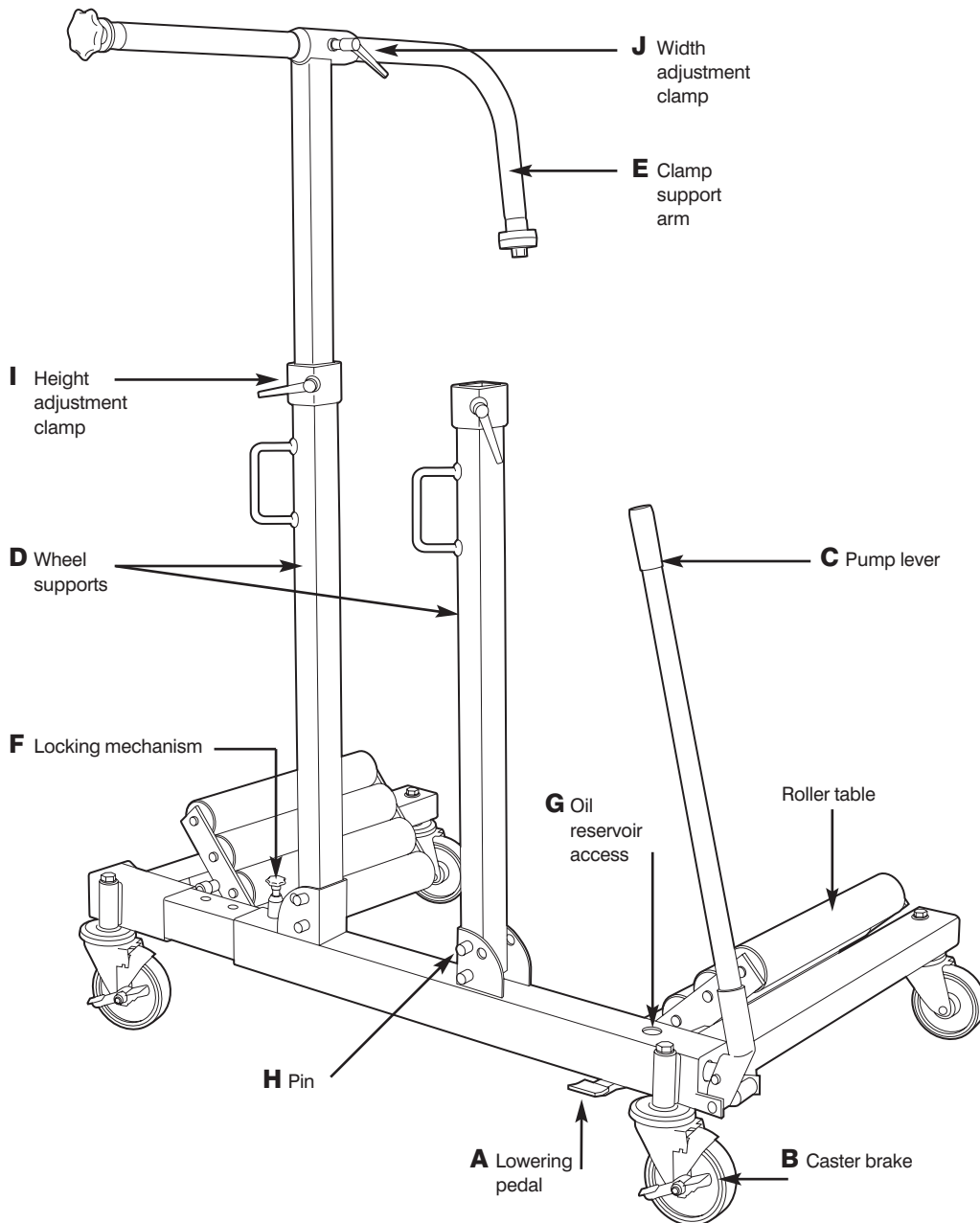

5.0 Refilling the hydraulic oil

Every 8 working hours:

- When re-filling the hydraulic oil reservoir, pump the Wheel Changer unit apart until the lifting rollers are to their widest possible position. With the unit at its widest possible reach remove the refill screw (G) and top-up the oil (ISO VG15). Re-filling is best carried out using a measuring jug with a flexible spout or an oil can.
- The oil used should be equivalent to hydraulic oil quality ISO VG15.

www.spaldings.co.uk

 SPALDINGS®

Spaldings Limited, Sadler Road, Lincoln LN6 3XJ
Tel: 01522 500600 • Fax: 0800 716040

Spaldings (Ireland) Limited, Moydrum Business Park, Athlone, Co. Westmeath
Tel: 090 6486008 • Fax: 090 6486133